



CMOS INTEGRATED DTMF TRANCEIVER

Features

- Advanced CMOS technology for low power consumption and increased noise immunity
- Complete DTMF
- Transmitter/Receiver
- Standard 8051, 8086/8 microprocessor port
- Central office quality and performance
- Adjustable guard time
- Automatic tone burst mode
- Call progress mode
- Single +5 volt power supply
- 20-pin DIP, 20-pin DIP EIAJ, 20-pin SOIC, 28-pin PLCC packages
- 2 MHz microprocessor port operation

Applications

- Paging systems
- Repeater systems/mobile radio
- Interconnect dialers
- PABX systems
- Computer systems
- Fax machines
- Pay telephones
- Credit card verification

Product Description

The CAMD CM8888/8888-2 is a fully integrated DTMF Transceiver, featuring adjustable guard time, automatic tone burst mode, call progress mode, and a fully compatible 8051, 8086/8 microprocessor interface. The CM8888/8888-2 is manufactured using state-of-the-art advanced CMOS technology for low power consumption and precise data handling. The CM8888/8888-2 is based on the industry standard CM8870 DTMF Receiver, while the transmitter utilizes a switched-capacitor D/A converter for low distortion, highly accurate DTMF signaling. Internal counters provide an automatic tone burst mode which allows tone bursts to be transmitted with precise timing. A call progress filter can be selected by an external microprocessor for analyzing call progress tones. The CM8888-2 is electrically equivalent to the CM8888 but does not include the call progress function.

Block Diagram

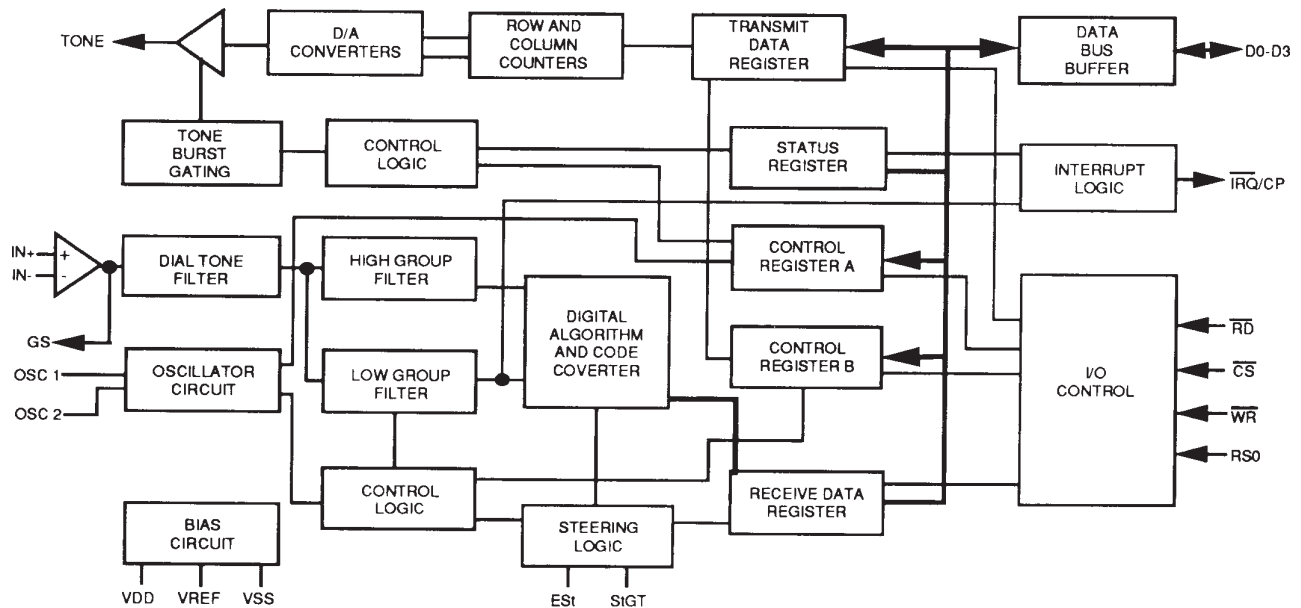

All trademarks are the property of their respective holders.



Absolute Maximum Ratings: (See Note)

ABSOLUTE MAXIMUM RATINGS		
Parameter	Symbol	Value
Power Supply Voltage ($V_{DD}-V_{SS}$)	V_{DD}	6.0V Max
Voltage on any Pin	Vdc	-0.3V to $V_{DD}+0.3V$
Current on any Pin	I_{DD}	10mA Max
Operating Temperature	T_A	-40°C to +85°C
Storage Temperature	T_S	-65°C to +150°C

This device contains input protection against damage due to high static voltages or electric fields; however, precautions should be taken to avoid application of voltages higher than the maximum rating.

Note:

Exceeding these ratings may cause permanent damage, functional operation under these conditions is not implied.

DC Characteristics: All voltages referenced to V_{SS} , $V_{DD} = 5.0V \pm 5\%$, $f_c = 3.579545$ MHz, $T_A = -40^\circ\text{C}$ to $+85^\circ\text{C}$ unless otherwise noted.

DC CHARACTERISTICS					
Parameter	Symbol	Min	Typ*	Max	Units
Operating Supply Voltage	V_{DD}	4.75	5.0	5.25	V
Operating Supply Current	I_{DD}		10		mA
Power Consumption	P_O			52.5	mΩ

Inputs

High Level Input Voltage OSCI	V_{IHO}	3.5			V
Low Level Input Voltage OSCI	V_{ILO}			1.5	V
Input Impedance, (@ 1KHz) IN+IN-	R_{IN}		10.0		MΩ
Steering Threshold Voltage ($V_{DD}=5.0V$)	V_{Tst}	2.2	2.3	2.5	V

Outputs

High Level Output Voltage (No Load) OSC2	V_{OHO}	4.9			V
Low Level Output Voltage (No Load) OSC2	V_{OLO}			0.1	V
Output Leakage Current ($V_{OH}=2..4V$) IRQ	I_{OZ}		1.0	10.0	μA
V_{REF} Output Voltage (No Load)	V_{REF}	2.4		2.7	V
V_{REF} Output Resistance	R_{OR}			1	KΩ

Data Bus (DO-D3, RD, WR, RSO, CS)

Low Level Input Voltage	V_{IL}			0.8	V
High Level Input Voltage	V_{IH}	2.0			V
Low Level Output Voltage ($I_{OL}=1.6mA$)	V_{OL}			0.4	V
High Level Input Voltage ($I_{OH}=400\mu A$)	V_{OH}	2.4			V
Input Leakage Current ($V_{IN}=0.4$ to $2.4V$) I	I_{IZ}			10.0	μA

Operating Characteristics - Gain Setting Amplifier: All voltages referenced to V_{SS} , $V_{DD} = 5.0V \pm 5\%$, $f_c = 3.579545$ MHz, $T_A = -40^\circ\text{C}$ to $+85^\circ\text{C}$ unless otherwise noted.

OPERATING CHARACTERISTICS					
Parameter	Symbol	Min	Typ	Max	Units
Input Leakage Current ($V_{SS} \leq V_{IN} \leq V_{DD}$)	I_{IN}		100		nA
Input Resistance	R_{IN}		10		MΩ
Input Offset Voltage	V_{OS}		25		mV
Power Supply Rejection (1 KHz)	PSRR		60		dB
Common Mode Rejection ($-3.0V \leq V_{IN} \leq 3.0V$)	CMRR		60		dB
DC Open Loop Voltage Gain	A_{VOL}		65		dB
Unity Gain Bandwidth	BW		1.5		MHz
Output Voltage Swing ($R_L \geq 100K\Omega$ to V_{SS})	V_O		4.5		V_{pp}
Maximum Capacitive Load (GS)	C_L		100		pF
Maximum Resistive Load (GS)	R_L		50		KΩ
Common Mode Range (No Load)	Vcm		3.0		V_{pp}



AC Characteristics: All voltages referenced to V_{SS} , $V_{DD} = 5.0V \pm 5\%$, $f_c = 3.579545$ MHz,
 $T_A = -40^\circ\text{C}$ to $+85^\circ\text{C}$ unless otherwise noted.

AC CHARACTERISTICS					
Parameter	Symbol	Min	Typ	Max	Units
Receive Signal Conditions					
Valid Input Signal Levels (Each Tone of Composite Signal; Notes 1,2,3,4,5,6,9)		-29 27.5		+1 869	dBm mV _{RMS}
Positive Twist Accept (Notes 2,3,6,9)				10	dB
Negative Twist Accept (Notes 2,3,6,9)				10	dB
Freq. Deviation Accept Limit (Notes 2,3,5,9)		$\pm 1.5\%$ $\pm 2\text{Hz}$			Nom.
Freq. Deviation Reject Limit (Notes 2,3,5)		$\pm 3.5\%$			Nom.
Third Tone Tolerance (2,3,4,5,9,10)			-16		dB
Noise Tolerance (2,3,4,5,7,9,10)			-16		dB
Dial Tone Tolerance (2,3,4,5,8,9,11)			22		dB
Lower Frequency (@ -25 dBm) ACCEPT	F_{LA}		320		Hz
Upper Frequency (@ -25 dBm) ACCEPT	F_{HA}		510		Hz
Lower Frequency (@ -25 dBm) ACCEPT	F_{LR}		290		Hz
Upper Frequency (@ -25 dBm) ACCEPT	F_{HR}		540		Hz
Receive Timing					
Tone Present Detection Time	t_{DP}	5	11	14	mS
Tone Absent Detection Time	t_{DA}	0.5	4	8.5	mS
Min Tone Duration Accept (Ref. Fig 9)	t_{REC}			40	mS
Max Tone Duration Reject (Ref. Fig 9)	t_{REC}	20			mS
Min. Interdigit Pause Accept (Ref. Fig 9)	t_{ID}			40	mS
Max. Interdigit Pause Reject (Ref. Fig 9)	t_{DO}	20			μS
Propagation Delay (St to b3)	$t_{PS}t_{b3}$		13		μS
Propagation Delay (St to RXO - RX3)	$t_{PS}t_{RX}$		8		μS
Transmit Timing					
Tone Burst Duration (DTMF Mode)	t_{BST}	50		52	mS
Tone Pause Duration (DTMF Mode)	t_{PS}	50		52	mS
Tone Burst Duration (Extended, Call Process Mode)	t_{BSTE}	100		104	mS
Tone Pause Duration (Extended, Call Process Mode)	t_{PSE}	100		104	mS
Tone Output					
High Group Output Level ($R_L = 10K\Omega$)	V_{HOUT}	-6.1		-2.1	dBm
Low Group Output Level ($R_L = 10K\Omega$)	V_{LOUT}	-8.1		-4.1	dBm
Pre-emphasis ($R_L = 10K\Omega$)	dBp	0	2	3	dB
Output Distortion ($R_L = 10K\Omega$ 3.4 KHz Bandwidth)	THD		-25		dB
Frequency Deviation ($f = 3.5795$ MHz)	f_D		± 0.7	± 1.5	%
Output Load Resistance	R_{LT}	10		50	K Ω



AC Characteristics: $V_{DD} = 5.0V \pm 5\%$, $V_{SS} = 0V$, $T_A = -40^\circ C$ to $+85^\circ C$

AC CHARACTERISTICS					
Parameter	Symbol	Min	Typ*	Max	Unit
Microprocessor Interface					
RD, WR, Low Pulse Width	t_{CL}	200			ns
RD, WR, High Pulse Width	t_{CH}	180			ns
RD, WR, Rise and Fall	t_R, t_F			25	ns
Address Hold	t_{AH}	10			ns
Address Setup	t_{AS}	23			ns
Read Data Hold	t_{DHR}	22			ns
RD to Valid Data Delay (200 pF Load)	t_{DDR}			150	ns
Write Data Setup	t_{DSW}	45			ns
Write Data Hold	t_{DHW}	10			ns
Input Capacitance DO-D3	t_{CIN}		5		pF
Output Capacitance IRQ CP	t_{OUT}		5		pF
DTMF Clock					
Crystal Clock Frequency	f_c	3.5759	3.5795	3.5831	MHz
Clock Input Rise Time (External Clk.)	t_{LHCL}			110	ns
Clock Input Fall Time (External Clk.)	t_{LHCL}			110	ns
Clock Input Duty Cycle (External Clk.)	DC_{CL}	40	50	60	%
Capacitive Load OSC2	C_{LO}			30	pF

* Typical values are for use as design aids only, and are not guaranteed or subject to production testing.

Notes:

1. dBm = decibels above or below a reference power of 1 mW into a 600 ohm load.
2. Digit sequence consists of all 16 DTMF tones.
3. Tone duration = 40mS. Tone pause = 40 mS.
4. Nominal DTMF frequencies are used.
5. Both tones in the composite signal have an equal amplitude.
6. The tone pair is deviate by $\pm 1.5\% \pm 2Hz$.
7. Bandwidth limited (3 KHz) Gaussian Noise.
8. The precise dial tone frequencies are 350 and 440 Hz ($\pm 2\%$)
9. For an error date of less than 1 in 10,000.
10. Referenced to the lowest amplitude tone in the DTMF signal.
11. Referenced to the minimum valid accept level.



Microprocessor Read Cycle

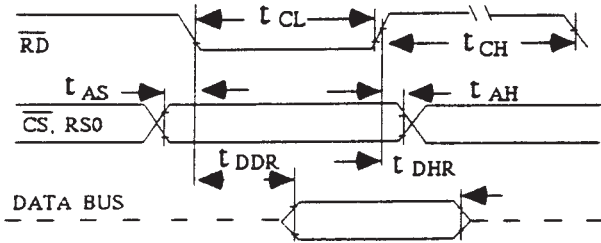

Microprocessor Write Cycle

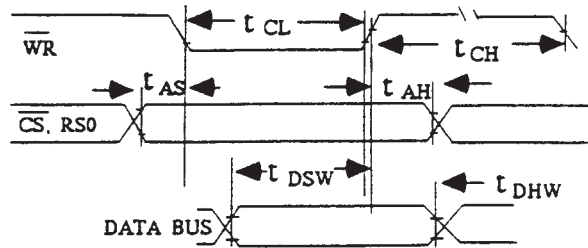

General Transceiver Timing

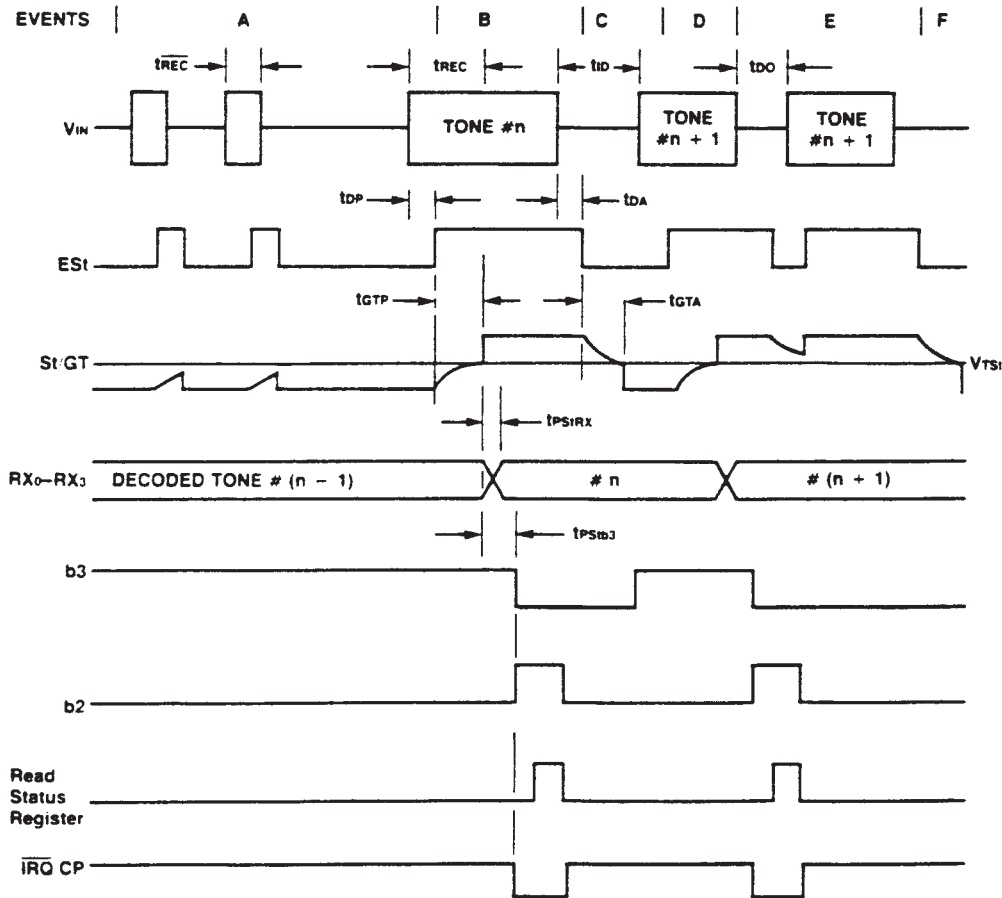



Explanation Of Events

- A. Tone bursts detected, tone duration invalid RX data register not updated.
- B. Tone #n detected, tone duration valid, tone decoded and latched in RX data register.
- C. End of tone #n detected, tone absent duration valid, information in RX data register retained until next valid tone pair.
- D. Tone #n + 1 detected, tone duration valid, tone decoded and latched in RX data register.
- E. Acceptance dropout of tone #n + 1, tone absent duration invalid, data remains unchanged.
- F. End of tone #n + 1 detected, tone absent duration valid, information in RX data register retained until next valid tone pair.

Explanation Symbols

- V_{IN} DTMF composite input signal.
- ES_t Early steering output, Indicates detection of valid tone frequencies.
- St/GT Steering input/guard time output. Drives external RC timing circuit.

- RX₀-RX₃ 4-bit decoded data in receive data register.
- b3 Delayed steering. Indicates that valid frequencies have been present/absent for the required guard time thus constituting a valid signal.
- b2 Indicates that valid data is in the receive data register. The bit is cleared after the status register is read.
- IRQ/CP Interupt is active indicating that new data is in the RX data register. The interupt is cleared after the status register is read.
- tREC Maximum DTMF signal duration not detected as valid.
- tREC Minimum DTMF signal duration required for valid recognition.
- t_{ID} Minimum time between valid sequential DTMF signals.
- t_{DO} Maximum allowable dropout during valid DTMF signal.
- t_{DP} Time to detect valid frequencies present.
- t_{DA} Time to detect valid frequencies absent.
- t_{GTP} Guard time, tone present.
- t_{GTA} Guard time, tone absent.

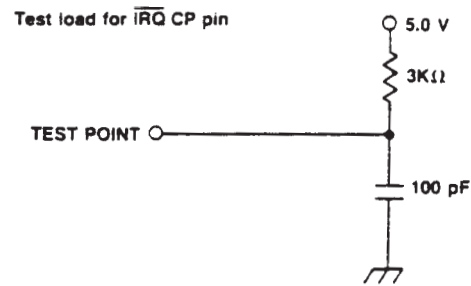
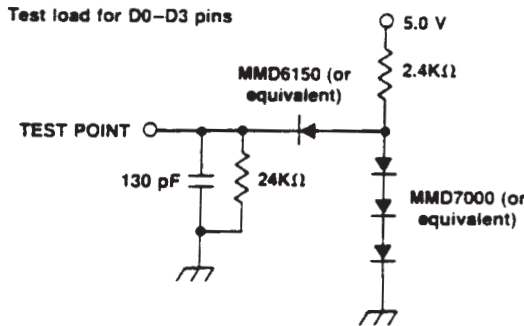

Functional Description

The CM8888 Integrated DTMF Transceiver provides the design engineer with not only low power consumption, but central office quality performance. The CM8888's internal architecture consists of high performance DTMF receiver with an internal Gain Setting Amplifier and DTMF generator. The DTMF Generator contains a Tone Burst Counter for generating precise tone bursts and pauses. The Call Progress mode, when selected, allows the detection of call progress tones. A standard 8051, 8086/8 series microprocessor interface allows access to an internal status register, two control registers and two data registers within the CM8888.

Input Configuration

The CM8888 input arrangement consists of a differential input operational amplifier and bias sources (V_{REF}) for biasing the amplifier inputs at V_{DD}/2. Provisions are made for the connection of a feedback resistor to the op amp output (GS) for gain adjustment. In the single-ended configuration, the input pins should be connected as shown in Figure 1, while Figure 2 shows the necessary connections for a differential input configuration.



Receiver Section

Separation of the low and high group tones is achieved by applying the DTMF signal to the inputs to two sixth order switched capacitor bandpass filters, the bandwidths of which correspond to the low and high-group frequencies as shown in Figure 5. The low-group filter incorporates notches at 350 Hz and 440 Hz for excellent dial-tone rejection. Each filter output is followed by a single-order switched capacitor filter section which smoothes the signals prior to limiting. Limiting is performed by high-gain comparators with hysteresis to prevent detection of unwanted low-level signals. The outputs of the comparators provide full-rail logic swings at the incoming DTMF signals frequencies.

Following the filter section is a decoder which employs digital counting techniques to determine the frequencies of the incoming tones, and to verify that the incoming tones correspond to standard DTMF frequencies. A complex averaging algorithm protects against tone simulation by extraneous signals (e.g. voice), while still providing tolerance to small deviations in frequency. The averaging algorithm was developed to ensure an optimum combination of immunity to talk-off, as well as a tolerance to the presence of two valid tones (sometimes referred to as "signal condition" in industry publications), the "Early Steering" (EST) output will go to an active state. Any subsequent loss of signal condition will cause EST to assume an inactive state.

Steering Circuit

Before registration of a decoded tone pair, the receiver

checks for a valid signal duration (referred to as Character Recognition Condition). This check is performed by an external RC time constant driven by EST. A logic high on EST causes VC (See Figure 3) to rise as the capacitor discharge. Provided that the signal condition is maintained (EST remains high) for the validation period (tGTP), VC reaches the threshold (VTSt) of the steering logic to register the tone pair, latching its corresponding 4-bit code (See Figure 5) into the Receive Data Register. At this point the GT continues to drive high as long as EST remains high. Finally, after a short delay to allow the output latch to settle, the Delayed Steering output flag goes high, signalling that a received tone pair has been registered. It is possible to monitor the status of the Delayed Steering flag by checking the appropriate bit in the Status Register. If Interrupt Mode has been selected, the IRQ/CP pin will pull low when the Delayed Steering flag is active.

The contents of the output latch are updated on an active Delayed Steering transition. This data is presented to the 4-bit bidirectional data bus when the Receive Data Register is read. The steering circuit works in reverse to validate the interdigit pause between signals. Thus, as well as rejecting signals too short to be considered valid, the receiver will tolerate signal interruptions (drop out) too short to be considered a valid pause. This facility, together with the capability of selecting the steering time constants externally, allows the designer to tailor performance to meet a wide variety of system requirements.

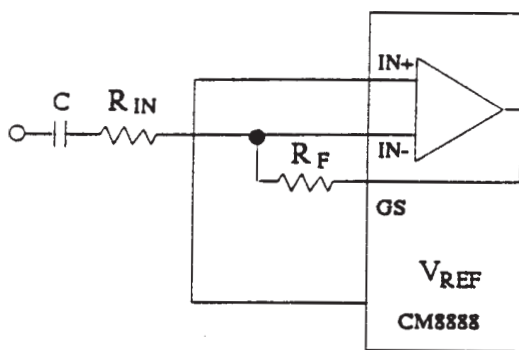

VOLTAGE GAIN

Figure 1. Single Ended Input Configuration

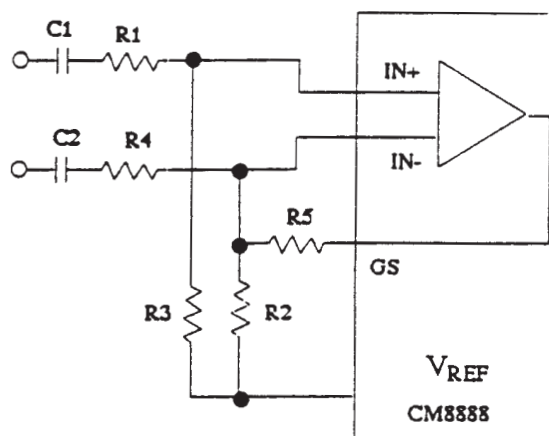

Figure 2. Differential Input Configuration



Guard Time Adjustment

The simple steering circuit shown in Figure 3 is adequate for most applications. Component values are chosen according to the formula:

$$t_{REC} = t_{DP} + t_{GTP}$$

$$t_{ID} = t_{DA} + t_{GTA}$$

The value of t_{DP} is a device parameter and t_{REC} is the minimum signal duration to be recognized by the receiver. A value for C of 0.1 uF is recommended for most applications, leaving R to be selected by the designer. Different steering arrangements may be used to select independently the guard times for tone present (t_{GTP}) and tone absent (t_{GTA}). This may be necessary to meet system specifications which place both accept and reject limits on both tone duration and interdigital pause. Guard Time adjustment also allows the designer to tailor system parameters such as talk-off and noise immunity. Increasing t_{REC} improves talk-off performance

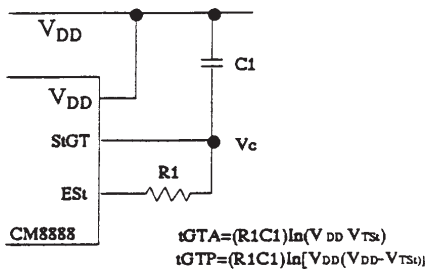

Figure 3. Basic Steering Circuit

since it reduces the probability that tones simulated by speech will maintain signal condition long enough to be registered. Alternatively, a relatively short t_{REC} with a long t_{DO} would be appropriate for extremely noisy environments where fast acquisition time and immunity to tone drop-outs are required. Design information for Guard Time adjustments is shown in Figure 4.

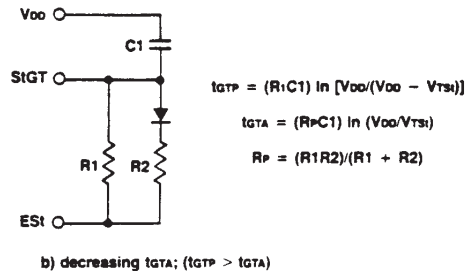
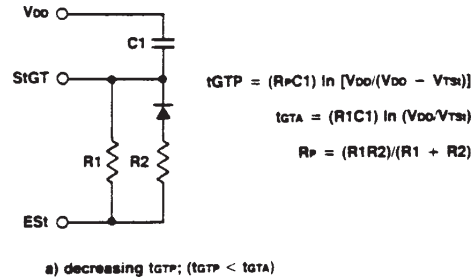

Figure 4. Guard Time Adjustment

Call Progress Filter (CM8888)

A Call Progress (CP) Mode can be selected allowing the detection of various tones which identify the progress of a telephone call on the network. The Call Progress tone input and DTMF input are common, however, call progress tones can only be detected when the CP Mode has been selected. DTMF signals cannot be detected if the CP Mode has been selected (see Table 5). Figure 6. indicates the useful detect bandwidth of the Call Progress filter. Frequencies presented to the input (IN + and IN-) which are within the 'accept' bandwidth limits of the filter are hard-limited by a high-gain comparator with the IRQ/CP pin serving as the output. The square wave output obtained from the schmitt trigger can be analyzed by a microprocessor or counter arrangement to determine the nature of the Call Progress tone being detected. Frequencies which are in the 'reject' area will not be detected, and consequently there will be no activity on IRQ/CP as a result of these frequencies.

FLOW	FHIGH	DIGIT	D3	D2	D3	DO
697	1209	1	0	0	0	1
697	1336	2	0	0	1	0
697	1477	3	0	0	1	1
770	1209	4	0	1	0	0
770	1336	5	0	1	0	1
770	1477	6	0	1	1	0
852	1209	7	0	1	1	1
852	1336	8	1	0	0	0
852	1477	9	1	0	0	1
941	1336	0	1	0	1	0
941	1209		1	0	1	1
941	1477	#	1	1	0	0
697	1633	A	1	1	0	1
770	1633	B	1	1	1	0
852	1633	C	1	1	1	1
941	1633	D	0	0	0	0

0=LOGIC LOW, 1=LOGIC HIGH

Figure 5. Function Encode/Decode



DTMF Generator

The DTMF transmitter employed in the CM888 is capable of generating all sixteen standard DTMF tone pairs with low distortion and high accuracy. All frequencies are derived from an external 3.58 MHz crystal. The sinusoidal waveforms for the individual tones are digitally synthesized using row and column programmable dividers and switched capacitor D/A converters. The row and column tones are mixed and filtered providing a DTMF signal, data conforming to the encoding format shown in Figure 5 must be written to the Transmit Data Register. Note that this is the same as the receiver output code. The individual tones which are generated (fLOW and fHIGH) are referred to as low-group and high-group tones. As seen from Table 1, the Low-Group frequencies are 697, 770, 852, and 941 Hz; the High-Group frequencies are 1209, 1336, 1477, and 1633 Hz. Typically the High-Group to Low-Group amplitude ratio (twist) is 2dB to compensate for High-Group attenuation on long loops.

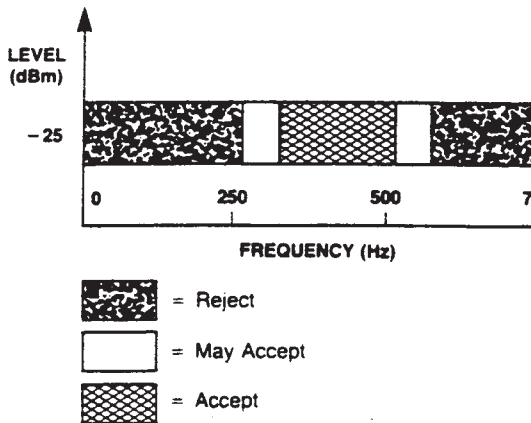

Figure 6 Call Progress Response

DTMF Generator Operation

The period of each tone consists of 32 equal time segments. The period of a tone is controlled by varying the length of these time segments. During write operations to the transmit data register, 4-bit data on the bus is latched and converted to of 8 coding for use by the programmable divider circuitry. This code is used to specify a time segment length which will ultimately determine the frequency for the tone. When the divider reaches the appropriate count as determined by the input code, a reset pulse is issued and the counter starts again. The number of time segments is fixed at 32; however, by varying the segment length as described above, the frequency can also be varied. The divider output clocks another counter which addresses the sinewave lookup ROM. The lookup table contains codes which are used by the switched capacitor D/A converter to obtain discrete and highly accurate DC voltage levels. Two identical

circuits are employed to produce row and column tones which are then mixed using a low noise summing amplifier. The oscillator described needs no "start-up" time as in other DTMF generators since the crystal oscillator is running continuously, thus providing a high degree of tone burst accuracy. Under conditions when there is no tone output signal, the TONE pin assumes a DC level of 2.5 volts (typ.) A bandwidth limiting filter is incorporated and serves to attenuate distortion products above 4 KHz. It can be seen from Figure 7 that the distortion products are very low in amplitude.

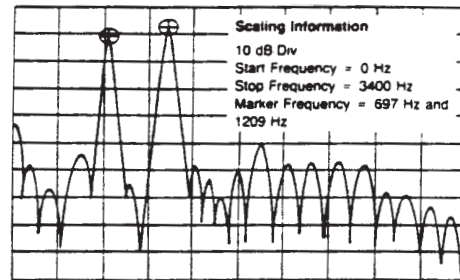

Figure 7 Spectrum Plot

Table 1 Actual Frequencies Versus Standard Requirements

ACTIVE CELL	OUTPUT FREQUENCY (Hz)		% ERROR
	SPECIFIED	ACTUAL	
L1	697	699.1	+0.30
L2	770	766.2	-0.49
L3	852	847.4	-0.54
L4	941	948.0	+0.74
H1	1209	1215.9	+0.57
H2	1336	1331.7	-0.32
H3	1447	1471.9	-0.35
H4	1633	1645.0	+0.73

Table 1 Actual Frequencies Versus Standard Requirements

Burst Mode

In certain telephony applications it is required that DTMF signals being generated be of a specific duration determined either by the particular application or by any one of the exchange transmitter specifications currently existing. Standard DTMF signal timing can be accomplished by making use of the Burst Mode. The transmitter is capable of issuing symmetric bursts/pauses of predetermined duration. This burst/pause duration is 51 mS + 1 mS which is a standard interval for autodialer and central office applications. After the burst pause has been issued, the appropriate bit is set in the Status Register, indicating that the transmitter is ready for more data. The timing described above is available when the DTMF Mode has been selected. However, when CP



Mode (Call Progress Mode is selected, a secondary burst/pause time is available such that this interval is extended to 102 mS + 2 mS. The extended interval is useful when precise tone bursts of longer than 51 mS duration and 51 mS pause are desired. Note that when CP mode and burst mode have been selected, DTMF tones may be transmitted only and not received. In certain applications where a nonstandard burst/pause time is desirable, a software timing loop or external timer can be used to provide the timing pulses when the burst mode is disabled by enabling and disabling the transmitter.

The CM8888 is initialized on power-up sequences such that DTMF mode and burst mode are selected. CP mode and burst mode have been selected, DTMF tones may be transmitted only and not received. In certain applications where a nonstandard burst/pause time is desirable, a software timing loop or external timer can be used to provide the timing pulses when the burst mode is disabled by enabling and disabling the transmitter.

The CM8888 is initialized on power-up sequence such that DTMF mode and burst mode are selected.

Single Tone Generation

A Single Tone Mode is available whereby individual tones from the low-group or high-group can be generated. This mode can be used for DTMF test equipment applications, acknowledgment tone generation and distortion measurements. Refer to Control Register B (Table 6) description for details.

Distortion Calculations

The CM8888 is capable of producing precise tone bursts with minimal error in frequency (See Table1). The internal summing amplifier is followed by a first-order low-pass switched-capacitor filter to minimize harmonic components and intermodulation products.

THD (%) = 100 * (sqrt(V21 + V31 + V41 + ... Vnf) / Vfundamental)

Equation 1. THD (%) For a Single Tone

THD (%) = 100 * (sqrt(V2L + V3L + VnL + V2H + V3H + ..VnH + VIMD) / sqrt(VL + VH))

Equation 2. THD (%) For a Dual Tone

The total harmonic distortion for a single tone can be calculated using Equation 1 which is the ratio of the total power of all the extraneous frequencies to the power of the fundamental frequency expressed as a percentage. The Fourier components of the tone output correspond to V2f...Vnf as measured on the output waveform. The total harmonic distortion for a dual tone can be

calculated using equation 2. VL and VH correspond to the low-group amplitude, respectively, and V2IMD is the sum of all the intermodulation components. The interval switched-capacitor filter following the D/A converter keeps distortion products down to a very low level as shown in Figure 7.

DTMF Clock Circuit

The internal clock circuit is complete with the addition of a standard television color burst crystal having a resonant frequency of 3.579545 MHz. A number of CM8888 devices can be connected as shown in Figure 8 such that only one crystal is required.

Figure 8 Common Crystal Connection

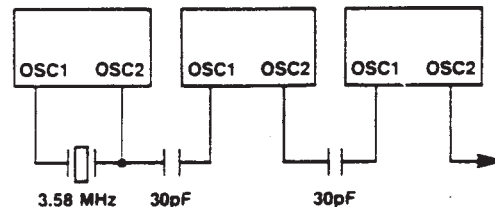

Table 2. Internal Register Functions

Table with 4 columns: RSO, RD, WR, Function. Rows include Write to Transmitter, Read from Receiver, Write to Control Register, and Read from Status Register.

Table 3. CRA Bit Positions

Table with 4 columns: b3, b2, b1, b0. Rows include RSEL, IRQ, CP DTMF, TOUT.

Table 4. CRA Bit Positions

Table with 4 columns: b3, b2, b1, b0. Rows include C/R, S/D, TEST, BURST.

Microprocessor Interface

The CM8888 employs a microprocessor interface which allows precise control of transmitter and receiver functions. There are five internal registers associated with the microprocessor interface which can be subdivided into three categories, ie; data transfer, transceiver control and transceiver status. There are two registers associated with



data transfer operations. The Receive Data Register contains the output code of the last valid DTMF tone pair to be decoded and is a read-only register. The data entered in the Transmit Data Register will determine which tone pair is to be generated (See Figure 5 for coding details). Data can only be written to the Transmit Data Register. Transceiver control is accomplished with two Control Registers (CRA and CRB) which occupy the same address space. A write operation to CRB can be executed by setting the appropriate bit in CRA. The following write operation to the same address will then be directed to CRB and subsequent write cycles will then be directed

back to CRA. Internal reset circuitry will clear the control registers on power-up; however, as a precautionary measure the initialization software should include a routine to clear the registers. Refer to Table 5 and 6 for details concerning the Control Registers. The IRQ/CP pin can be programmed such that it will provide an interrupt request signal upon validation of DTMF signals, or when the transmitter is ready for more data (Burst mode only). The IRQ/CP pin is configured as an open-drain output device and as such requires a pull-up resistor (See Figure 9).

Table 5. Control Register A Description

CONTROL REGISTER A DESCRIPTION			
Bit	Name	Function	Description
b0	TOUT	Tone Output	A logic '1' enables the Tone Output. This function can be implemented in either the Burst Mode or Non-Burst Mode.
b1	CP/DTMF	Mode Control	In DTMF (logic '0'), the device is capable of generating and receiving Dual Tone Multi-Frequency signals. When the CP (Call Progress) mode is selected (logic '1'), a 6th order bandpass filter is enabled to allow Call Progress tones to be detected. Call Progress tones which are within the specified bandwidth will be presented at the IRQ/CP pin in rectangular wave format if the IRQ bit has been enabled (B2=1). Also when the CP mode and Burst Mode have both been selected, the transmitter will issue DTMF signal with a burst and pause of 102 mS (typ) duration. This signal duration is twice that obtained from the DTMF transmitter, if DTMF mode had been selected. Note that signals cannot be decoded when the CP mode of operation has been selected.
b2	IRQ	Interrupt Enable	A logic '1' enables the Interrupt Mode. When this mode is active and the DTMF Mode has been selected (b1=0), the IRQ/CP pin will pull to a logic '0' condition when either 1) a valid DTMF signal has been received and has been present for the guard time duration or 2) the transmitter is ready for more data (Burst Mode only).
b3	RSEL	Register	A logic '1' selects Control Register B on the next write cycle to the Control Register address. Subsequent write cycles to the Control Register are directed back to Control Register A.



Table 6. Control Register B Description

Bit	Name	Function	Description
b0	BURST	Burst Mode	A logic '0' enables the Burst Mode. When this mode is selected, data corresponding to the desired DTMF tone pair can be written to the Transmit Data Register, resulting in a tone burst of a specific duration (See AC Characteristics). Subsequently, a pause of the same duration is induced. Immediately following the pause, the Status Register is updated indicating that the Transmit Data Register is ready for further instructions, and an interrupt will be generated if the Interrupt Mode has been enabled. Additionally, if Call Progress (CP) Mode has been enabled, the burst and pause duration is increased by a factor of two. When the Burst Mode is not selected (logic '1') tone bursts of any desired duration may be generated.
b1	TEST	Test Mode	By enabling the Test Mode (logic '1') the $\overline{\text{IRQ/CP}}$ pin will present the delayed steering (inverted) signal from the DTMF receiver. Refer to General Transceiver Timing (b3 waveform) for details concerning the output waveform. DTMF Mode must be selected (CRA b1 = 0) before Test Mode can be implemented.
b2	S/D	Single/Dual Tone Generation	A logic '0' will allow Dual Tone Multi-Frequency signals to be produced. If single-tone generation is enabled (logic '1'), either row or column tones (low-group or high-group) can be generated depending on the state of b3 in Control Register B.
b3	C/R	Column/Row Tones	When used in conjunction with b2 (above) the transmitter can be made to generate single-row or single-column frequencies. A logic '0' will select row frequencies and a logic '1' will select column frequencies.

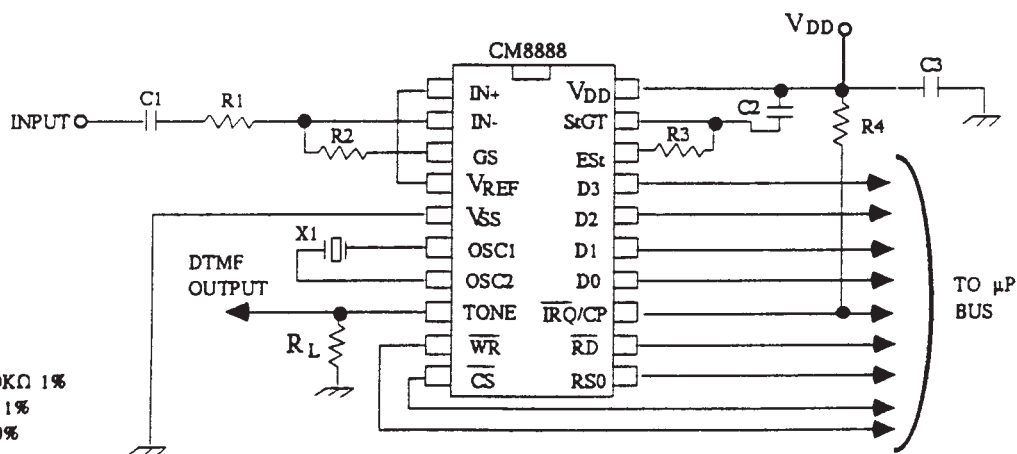

- Notes:
 R1, R2 = 100KΩ 1%
 R3 = 374KΩ 1%
 R4 = 3KΩ 10%
 RL = 10KΩ (min)
 C1 = 100 nF 5%
 C2 = 100 nF 5%
 C3 = 100 nF 10%
 X1 = 3.579545 MHz

* Microprocessor based systems can inject undesirable noise into the supply rails. The performance of the CM8888 can be optimized by keeping noise on the supply rails to a minimum. The decoupling capacitor (C3) should be connected close to the device and ground loops should be avoided.



Table 7. Status Register Description

Bit	Name	Status Flag Set	Status Flag Cleared
b0	IRQ	Interrupt has occurred. Bit one (b1) and/or bit two (b2) is set.	Interrupt is inactive. Cleared after Status Register is read.
b1	Transmit Data Register	Pause duration has terminated and transmitter is ready for new data.	Cleared after Status Register is read or when in Non-Burst Mode.
b2	Receive Data Register Full	Valid data is in the Receive Data Register.	Cleared after Status Register is read.
b3	Delayed Steering	Set upon the valid detection of the absence of a DTMF signal.	Cleared upon the detection of a valid DTMF signal.

Pin Function Table

Name	Description
N+	Non-inverting op-amp input.
IN-	Inverting op-amp input
GS	Gain Select. Gives access to output of front end differential amplifier for connection of feedback resistor.
V _{REF}	Reference voltage output. Nominally V _{DD} /2 is used to bias inputs at mid-rail (see application circuit).
V _{SS}	Negative power supply input.
OSC1	DTMF clock/oscillator input.
OSC2	Clock output. A 3.5795 MHz crystal connected between OSC1 AND OSC2 completes the internal oscillator circuit.
TONE	Dual tone Multi-Frequency (DTMF) output.
WR	Write input. A low on this pin when CS is low enables data transfer from the microprocessor. TTL compatible.
CS	Chip Select. TTL input. (CS = 0 to select the chip).
RSO	Register select input. See register decode table. TTL compatible.
RD	Read input. A low on this pin when CS is low enables data transfer to the microprocessor. TTL compatible.

Name	Description
IRQ/CP	Interrupt request to microprocessor (open-drain output). Also, when Call Progress (CP) Mode has been selected and Interrupt enabled the IRQ/CP pin will output a rectangular wave signal representative of the input signal applied at the input op-amp. The input signal must be within the bandwidth limits of the Call Progress filter. See Filter 6.
DO-D3	Microprocessor data bus. TTL compatible.
Est	Early Spring output. Presents a logic high once the digital algorithm has detected a valid tone pair (signal condition). Any momentary loss of signal condition will cause EST to return to a logic low.
StGT	Steering input/Guard Time output (bidirectional). A voltage greater than V _{TS} , detected at St causes the device to register the detected tone pair and update the output latch. A voltage less than V _{TS} , frees the device to accept a new tone pair. The GT output acts to reset the external steering time-constant; its state is a function of Est and the voltage on St.
V _{DD}	Positive power supply input.